

improvements are obtained by installation of a Zeta Rod system:

- Scale formation and odor in the evaporative coolers is eliminated.
- Pad life is extended to 2 to 3 years for aspen pads, even longer for Celdek™* media.
- Service life of the cooler frame and body is lengthened by 50% or more.
- Water consumption is reduced by 25% or more while maintaining the full design efficiency of the coolers.
- Payback of the Zeta Rod system purchase price from operational savings is normally less than a year.

PROVEN RELIABILITY

With scores of installations spanning 5 years, the Zeta Rod system has proven itself in operation over a wide range of applications.

All Zeta Rod products carry a three year warranty against defects in parts and labor.

HOW TO PURCHASE

The Zeta Rod for Evaporative Coolers is available in three standard sizes and as a custom-designed system. Call or email ZETA CORPORATION for more information or a quotation on a system to meet your needs.

*Celdek™ is a trademark of another company.

Copyright ©2000 ZETA CORPORATION. All rights reserved.



ZETA CORPORATION

2045 N. Forbes Blvd. • Suite 102
Tucson, AZ • 85745 • USA
tel - 888.785.9660
fax - 520.903.9910

email - coolers@zetacorp.com

web - <http://www.zetacorp.com/coolers/>

PRSR STD
US POSTAGE
PAID
TUCSON, AZ
PERMIT 550

ZETA CORPORATION

2045 N. Forbes Blvd. • Suite 102
Tucson, AZ • 85745 • USA

If you are operating
**Evaporative
Coolers**
the "Old Way,"
it's time
to apply
**New
Water Treatment
Technology.**

ZETA ROD™ Electro-Chemical Scale and Odor Control for Commercial and Industrial Evaporative Cooler Installations

THE PROBLEM

The hassle of evaporative cooler operation is only justified by the relatively low capital and energy cost compared to cooling with refrigeration equipment. Common problems with evaporative coolers include:

- Heavy scale formation, fishy odors and high maintenance costs are commonly accepted as unavoidable in the operation of evaporative coolers.
- Salty scale encrustation on the exterior of the cooler housing penetrates the protective finish and accelerates corrosion.
- Scale fills the pore space of the cooler pads and fills the louvers of the housing panels restricting air flow and reducing the output of cool air. Media efficiency and service life is reduced
- Scale accumulation inside the pumps and tubing reduces water flow and cooling efficiency.

- Scale causes float valves to stick open or closed requiring higher expenditures for labor and parts. Maintenance costs become unacceptably high.
- Bacterial growth produces foul odors and can present a threat to human health.

THE ZETA ROD™ SYSTEM

The Zeta Rod system is used for control of scale and biofouling in large industrial, commercial, and process cooling applications. The basic design features of the large industrial Zeta Rod systems have been retained in the design adapted for evaporative coolers.

The Zeta Rod for evaporative coolers consists of a ceramic electrode centered inside a stainless steel-lined reaction chamber through which water flows before entering the evaporative coolers. The electrode is energized by a power supply which is sealed inside an impact resistant NEMA 4X-rated housing.

HOW IT WORKS

The power supply produces a voltage of 35 kV at low current that is delivered to the Zeta Rod electrode. The grounded stainless steel lining of the reaction chamber around the high voltage electrode forms a powerful cylindrical capacitor. As water flows through the chamber, the tiny scale-forming particles present receive a strong boost to their natural surface charge. The more

Zeta Rod for Evaporative Coolers - Typical Installation

Up to 30 units can be operated from a single Zeta Rod system.

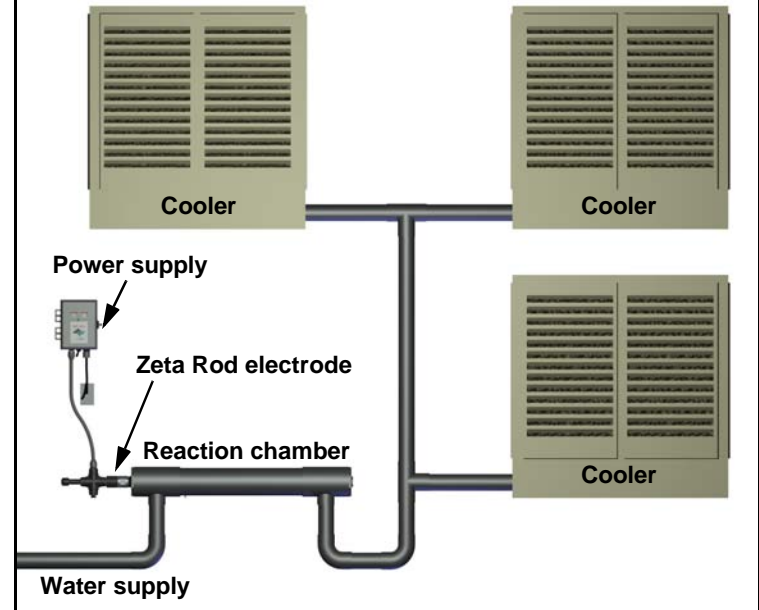

strongly charged particles repel one another and remain in stable suspension rather than uniting to form scale deposits.

This repelling action also inhibits formation of microbial colonies (patent pending). The reduction in the growth of bacteria eliminates the principal cause of foul odors from which the name "swamp cooler" originated.

BENEFITS

With the addition of a Zeta Rod system, evaporative cooler operation becomes a truly low-maintenance, high-performance cooling solution. The following

